

Name: Last _____, First _____

MULTIPLE CHOICE. Choose the one alternative that best completes the statement or answers the question.

Find the distance $d(P_1, P_2)$ between the points P_1 and P_2 .

1)

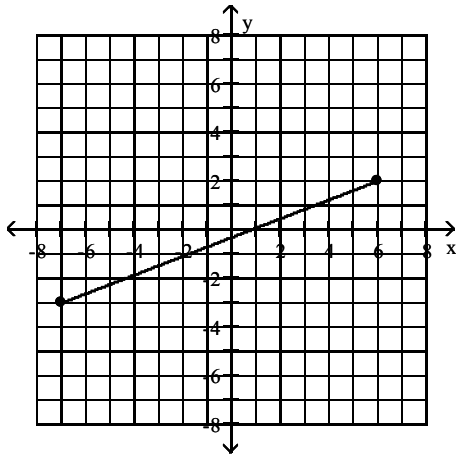

1) _____

A) $\sqrt{194}$

B) 65

C) 8

D) 12

2) $P_1 = (4, -7); P_2 = (6, -1)$

2) _____

A) 4

B) $32\sqrt{2}$

C) $2\sqrt{10}$

D) 32

Decide whether or not the points are the vertices of a right triangle.

3) $(5, -8), (11, -6), (17, -13)$

3) _____

A) Yes

B) No

Solve the problem.

4) Find all values of k so that the given points are $\sqrt{29}$ units apart.
 $(-5, 5), (k, 0)$

4) _____

A) 7

B) -3, -7

C) -7

D) 3, 7

Find the midpoint of the line segment joining the points P_1 and P_2 .

5) $P_1 = (0.8, -0.5); P_2 = (2.9, -2.7)$

5) _____

A) $(-1.1, 1.05)$

B) $(1.85, -1.6)$

C) $(-1.6, 1.85)$

D) $(1.05, -1.1)$

Solve the problem.

6) If $(6, -3)$ is the endpoint of a line segment, and $(2, -2)$ is its midpoint, find the other endpoint.

6) _____

A) $(8, -11)$

B) $(-2, -1)$

C) $(14, -5)$

D) $(-2, -4)$

List the intercepts of the graph.

7)

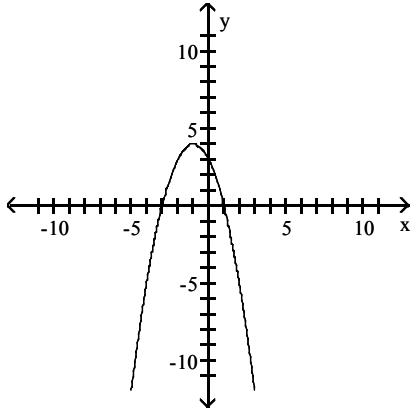

7) _____

A) $(0, -3), (3, 0), (0, 1)$

B) $(-3, 0), (0, 3), (1, 0)$

C) $(0, -3), (0, 3), (1, 0)$

D) $(-3, 0), (0, 3), (0, 1)$

List the intercepts for the graph of the equation.

8) $y = x^2 + 14x + 48$

8) _____

A) $(6, 0), (8, 0), (0, 48)$

B) $(0, 6), (0, 8), (48, 0)$

C) $(0, -6), (0, -8), (48, 0)$

D) $(-6, 0), (-8, 0), (0, 48)$

9) $y = \frac{x^2 - 64}{8x^4}$

9) _____

A) $(-8, 0), (8, 0)$

B) $(0, 0)$

C) $(0, -8), (0, 8)$

D) $(-64, 0), (0, 0), (64, 0)$

Draw a complete graph so that it has the given type of symmetry.

10) Symmetric with respect to the x-axis

10) _____

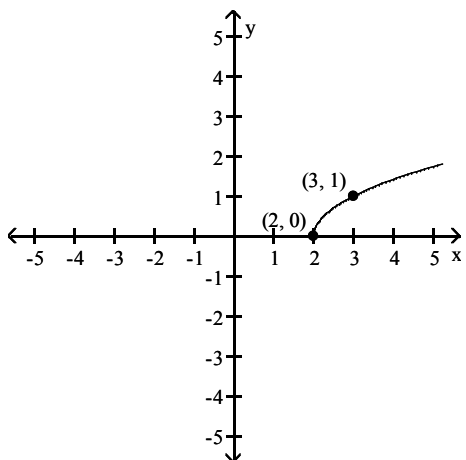

A)

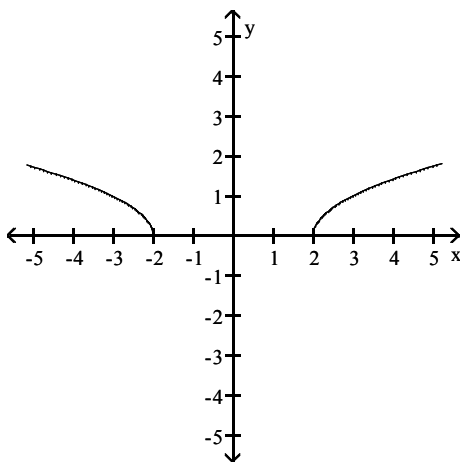

B)

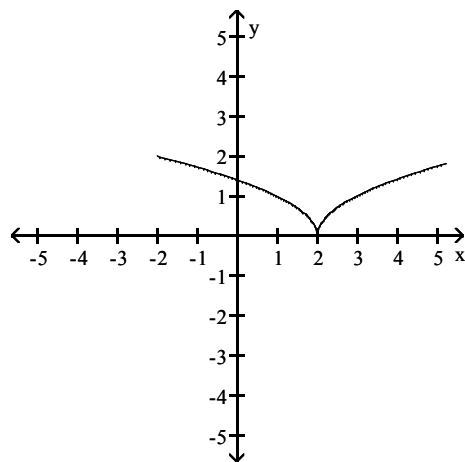

C)

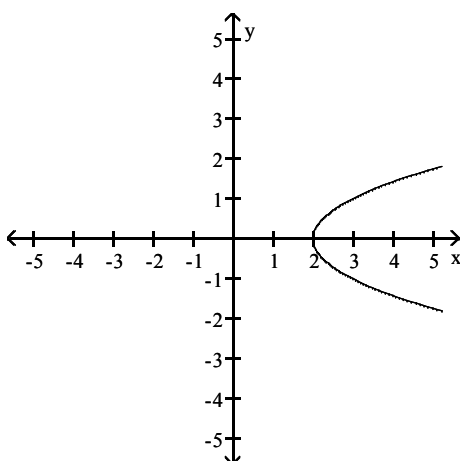

D)

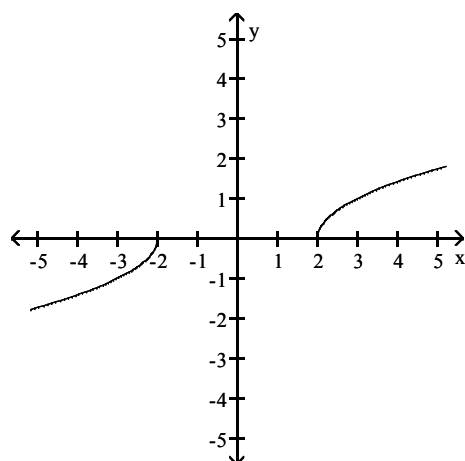

Graph the equation by plotting points.

$$11) y = \frac{1}{x}$$

11) _____

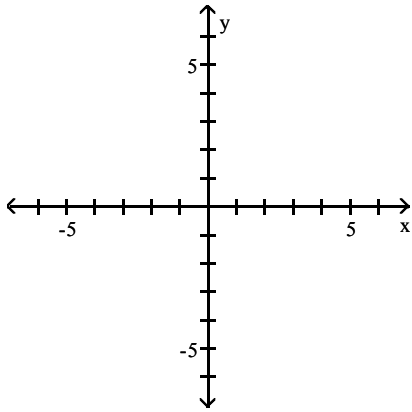

A)

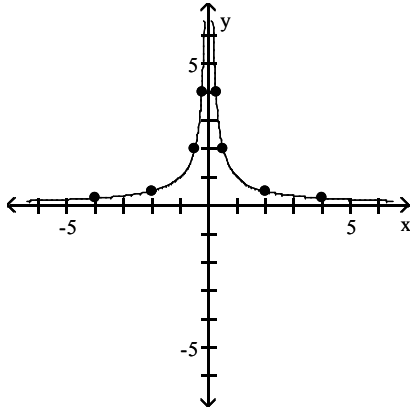

B)

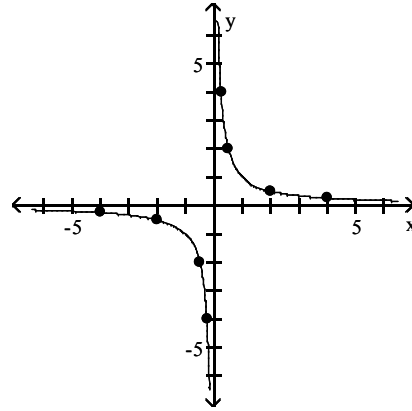

C)

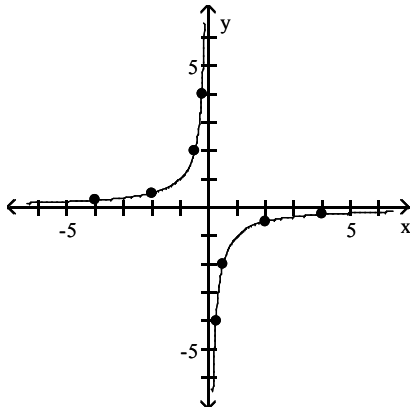

D)

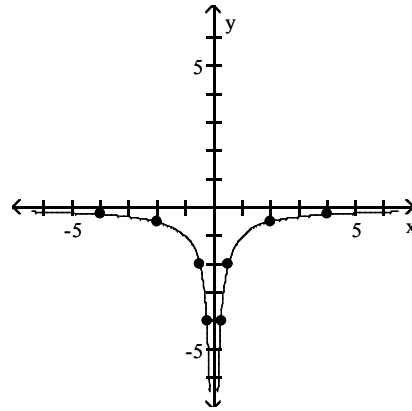

12) $x = y^2$

12) _____

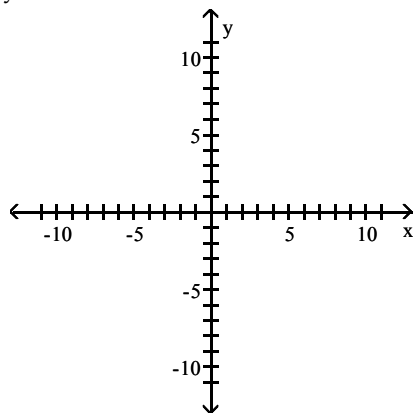

A)

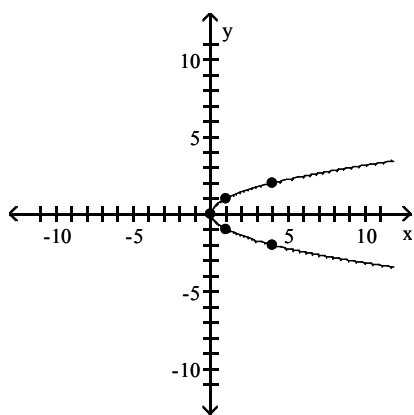

B)

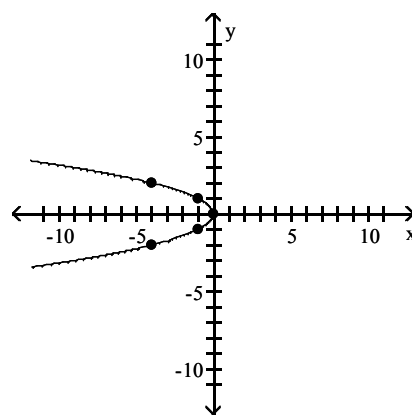

C)

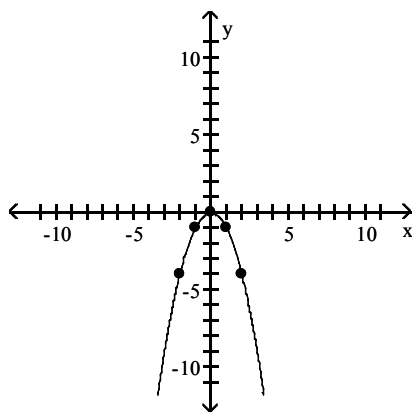

D)

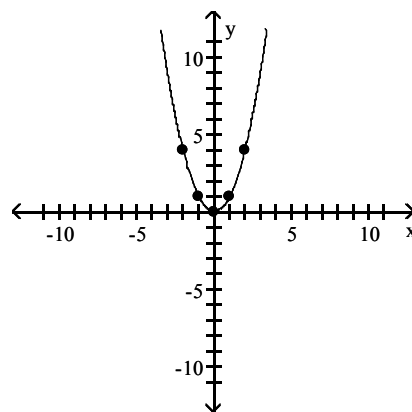

List the intercepts of the graph. Tell whether the graph is symmetric with respect to the x-axis, y-axis, origin, or none of these.

13)

13) _____

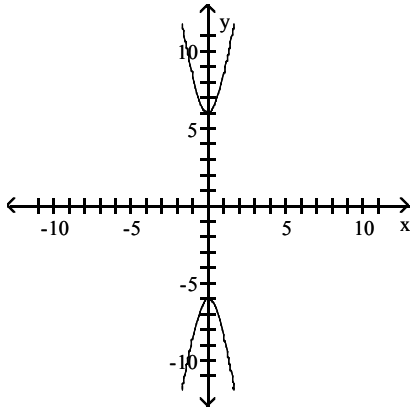

- A) intercepts: (0, 6) and (0, -6)
symmetric with respect to x-axis, y-axis, and origin
- B) intercepts: (6, 0) and (-6, 0)
symmetric with respect to y-axis
- C) intercepts: (6, 0) and (-6, 0)
symmetric with respect to x-axis, y-axis, and origin
- D) intercepts: (0, 6) and (0, -6)
symmetric with respect to origin

Find the slope of the line containing the two points.

14) (8, 0); (0, 5)

14) _____

- A) $\frac{5}{8}$
- B) $-\frac{5}{8}$
- C) $\frac{8}{5}$
- D) $-\frac{8}{5}$

Find an equation for the line, in the indicated form, with the given properties.

15) Containing the points (-4, -8) and (-3, 7); slope-intercept form

15) _____

- A) $y + 8 = 15(x + 4)$
- B) $y = mx + 52$
- C) $y = -15x + 52$
- D) $y = 15x + 52$

16) Containing the points (2, -7) and (0, 8); general form

16) _____

- A) $-9x + 8y = -64$
- B) $-15x + 2y = 16$
- C) $15x + 2y = 16$
- D) $9x - 8y = -64$

Solve.

17) When making a telephone call using a calling card, a call lasting 3 minutes cost \$1.60. A call lasting 10 minutes cost \$4.40. Let y be the cost of making a call lasting x minutes using a calling card.

17) _____

Write a linear equation that relates the cost of a making a call, y, to the time x.

- A) $y = -0.4x + 2.8$
- B) $y = 0.4x + 0.4$
- C) $y = \frac{5}{2}x - \frac{59}{10}$
- D) $y = 0.4x - 5.6$

- 18) The average value of a certain type of automobile was \$14,100 in 1991 and depreciated to \$8040 in 1995. Let y be the average value of the automobile in the year x , where $x = 0$ represents 1991. Write a linear equation that relates the average value of the automobile, y , to the year x . 18) _____

A) $y = -1515x + 1980$

B) $y = -1515x + 8040$

C) $y = -\frac{1}{1515}x - 8040$

D) $y = -1515x + 14,100$

Find an equation for the line with the given properties.

- 19) Parallel to the line $2x + 9y = 24$; containing the point $(3, -6)$ 19) _____

A) $2x - 9y = -48$

B) $9x + 2y = -6$

C) $3x + 9y = 24$

D) $2x + 9y = -48$

- 20) Perpendicular to the line $y = \frac{1}{9}x + 8$; containing the point $(3, -2)$ 20) _____

A) $y = -9x - 25$

B) $y = 9x - 25$

C) $y = -9x + 25$

D) $y = -\frac{1}{9}x - \frac{25}{9}$

Write the standard form of the equation of the circle with radius r and center (h, k) .

- 21) $r = \sqrt{6}$; $(h, k) = (-1, 6)$ 21) _____

A) $(x + 6)^2 + (y - 1)^2 = 36$

B) $(x - 6)^2 + (y + 1)^2 = 36$

C) $(x + 1)^2 + (y - 6)^2 = 6$

D) $(x - 1)^2 + (y + 6)^2 = 6$

Find the center (h, k) and radius r of the circle. Graph the circle.

22) $x^2 + y^2 - 12x - 8y + 48 = 0$

22) _____

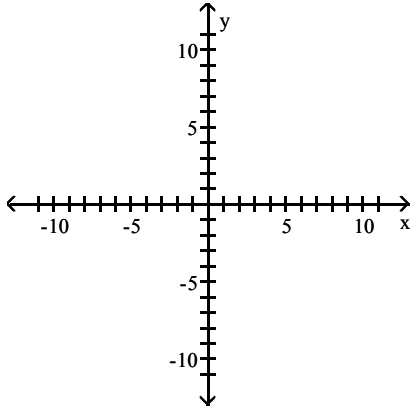

A) $(h, k) = (6, -4); r = 2$

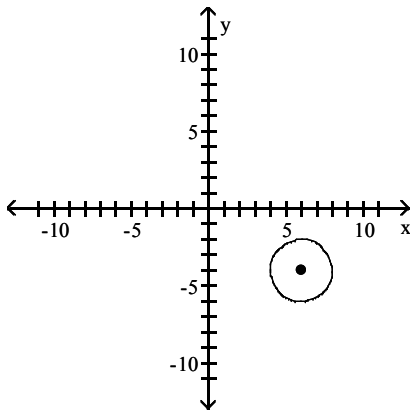

B) $(h, k) = (6, 4); r = 2$

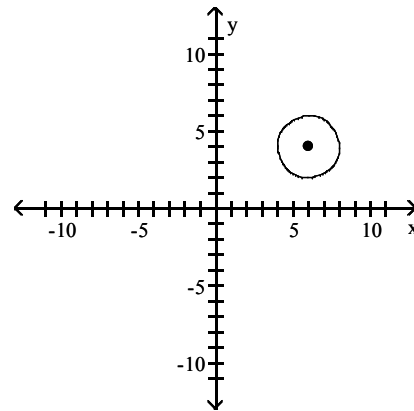

C) $(h, k) = (-6, 4); r = 2$

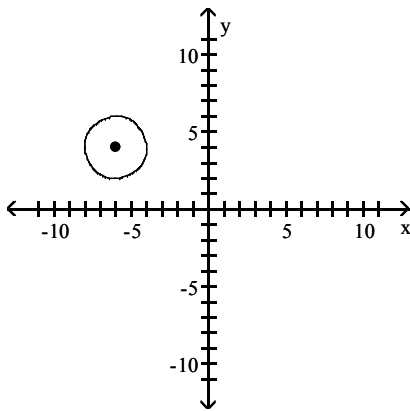

D) $(h, k) = (-6, -4); r = 2$

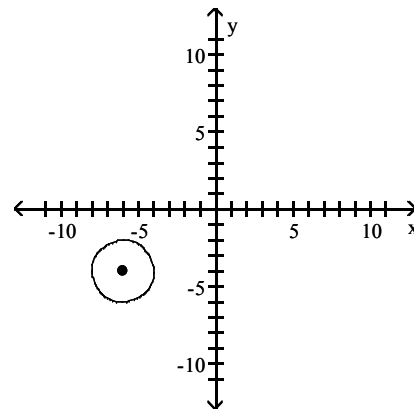

Solve the problem.

23) A power outage affected all homes and businesses within a 4 mi radius of the power station. If the power station is located 1 mi west and 3 mi north of the center of town, find an equation of the circle consisting of the furthest points from the station affected by the power outage.

23) _____

A) $(x - 1)^2 + (y - 3)^2 = 16$

B) $(x + 1)^2 + (y + 3)^2 = 16$

C) $(x + 1)^2 + (y - 3)^2 = 16$

D) $(x - 1)^2 + (y + 3)^2 = 16$

- 24) In simplified form, the period of vibration P for a pendulum varies directly as the square root of its length L . If P is 1 sec. when L is 4 in., what is the period when the length is 36 in.?
- A) 3 sec B) 72 sec C) 12 sec D) 18 sec

- 25) x varies inversely as y^2 , and $x = 6$ when $y = 10$. Find x when $y = 2$.
- A) $x = 150$ B) $x = 5$ C) $x = 24$ D) $x = 180$

Write a general formula to describe the variation.

- 26) The square of G varies directly with the cube of x and inversely with the square of y ; $G = 4$ when $x = 4$ and $y = 6$
- A) $G^2 = 6 \frac{x^3}{y^2}$ B) $G^2 = \frac{1}{144} (x^3 + y^2)$
- C) $G^2 = 9 \frac{x^3}{y^2}$ D) $G^2 = \frac{256}{9} \frac{y^3}{x^2}$

Answer Key

Testname: MATH 1111 Q2 V1-FALL-08

- 1) A
- 2) C
- 3) B
- 4) B
- 5) B
- 6) B
- 7) B
- 8) D
- 9) A
- 10) C
- 11) B
- 12) A
- 13) A
- 14) B
- 15) D
- 16) C
- 17) B
- 18) D
- 19) D
- 20) C
- 21) C
- 22) B
- 23) C
- 24) A
- 25) A
- 26) C